

ORISSAN DESIGN INSPIRED SYSTEMS & AEROVEHICLES [ODISA] : A CONCEPT

POOJA BHATTACHARYA and SWASTIKA BHATTACHARYA

1 - Std. XI, B.J. B College, Lewis Road, Bhubaneswar, India

2 - Std. IX St. Xavier's High School, Kedar Gouri, Bhubaneswar, India, 751002.

C/o Radha Krishna, Kedar Gouri Road, Bhubaneswar-751002, India.

Phone 91(0)674-2430407 (Resi), E. mail (pp)- oddisilab1@dataone.in

Introduction

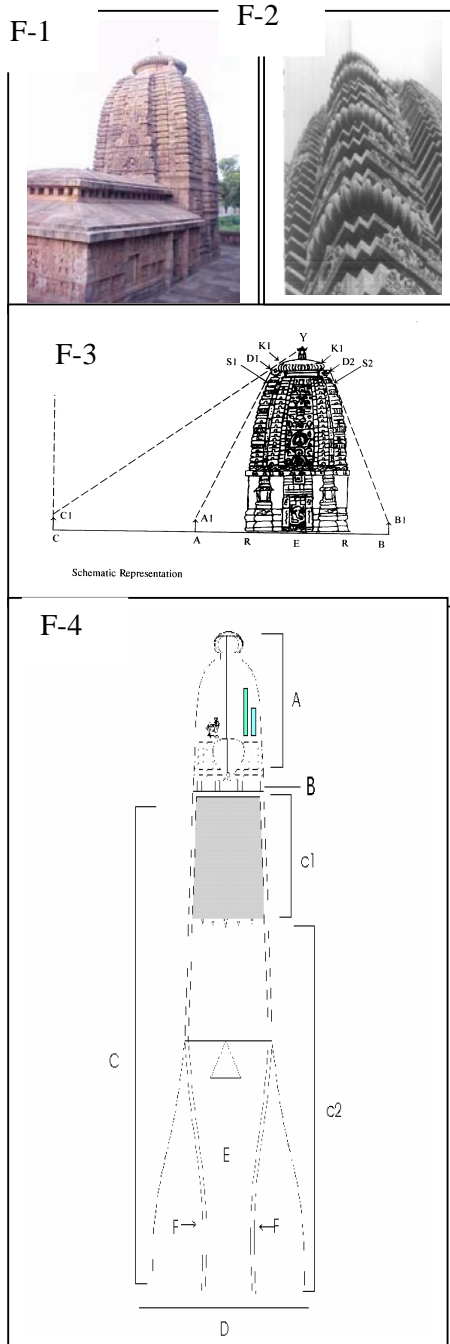

The space is not fragile. In space humans are. Space settlement is a logical step forward and also a technological necessity. In this essay we try to present a concept of a imaginary rocket. Our aim is to give a original idea/concept, make it economic and very powerful, so that it may be able to lift very high load into space up to geo-stationary orbit or to the moon and also have a large workshop. It is necessary to join and serve the multi-lateral objective of habitable space settlements. In front of our school are the world famous monuments of Parashurameswar, c.650 A.D. [Fig.1,3], Mukteswar and Lingaraj c. 9th & 10th A.D respectively. The architecture of these temples are called *kalingiya bakrakara rekha vimana* (clever & intelligent curvilinear aero-vehicles). They are curvilinear [Fig.2], tapering at top and widening at base with ribbed roses called *Bhumi anla* at corners.

The side walls have vertical niches called *rekha* (lines). Therefore, the niches are also curvilinear along which the cool breeze plays up & down even on a breezeless, hot, sultry day. The local people call the upper portion as *VIMANA* (aero-vehicle). This makes the whole a original concept. This is the source of our inspiration. Since we do not know rocket science, we hereinafter imagine a concept based on such superficial observations. Therefore, we adopt a schematic route of presentation. We also borrow terms from scientists, parents, & teachers to make our presentations more attractive and suggestively more applicative [N-1]. They are marked with the sign [*]. Fig. 1 is the photograph of Parashurameswar temple Fig. 2 is the *Bhumi anla* series of Mukteswar. Fig.3 is a sketch diagram that we have borrowed from our father. Dotted lines C1-Y show the lines of wind in a wind tunnel [*]. A1-D1 and B1-D2 show the lines of wind with model. Fig. 4 is the schematic presentation of our *Vimana* inspired rocket. We have made it slim so that it is in tune with standard concepts. The great temples of Lingaraj, Puri & Konarak were built

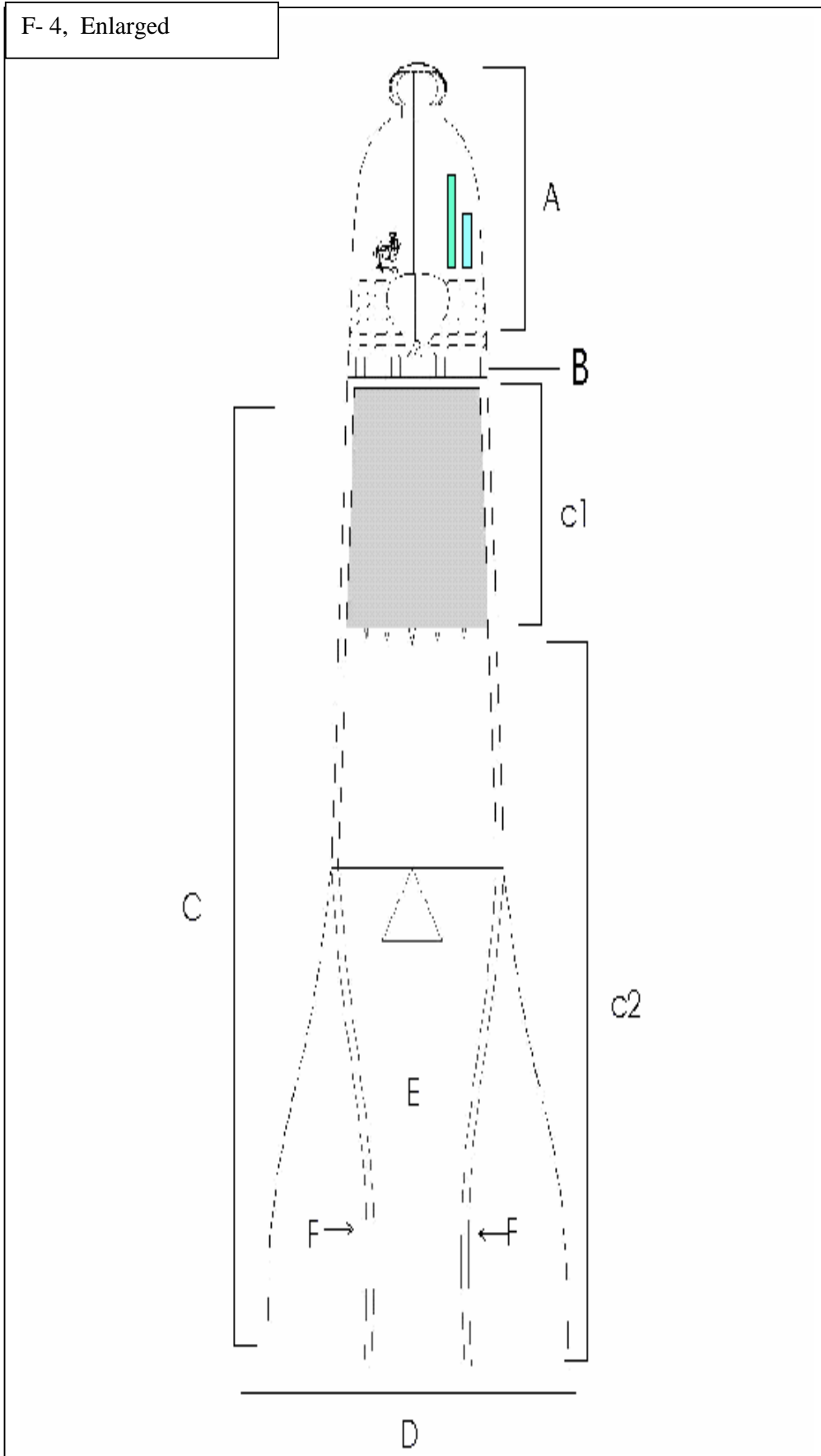

by *Gajapati* emperors, who were also popularly known as *Gajaraj* (the Lord of Tuskers). Orissa our homeland is also home to the best and the mightiest tusker of the Asian stock. In the Hindu way of life, Ganesa is the lord of all auspicious beginnings and successful termination. In Orissa, in c.9th A.D. Ganesa was known as *Gajasya* which is the *prakrit* (original phonetics) variant of *Gajaraj* (tusker lord), which in turn was the popular call name of the native medieval emperors, along with a variant *Gajapati*. Pre Industrial revolution the tusker has been used in all major construction and power related activity. India is a land of tradition, culture, custom, history and heritage. To build space colonies lot of material has to be hauled up. We intend massive power, high efficiency, fail safe performance, and never before economy. Since all these (if done) constitute 'wish fulfillment', we have borrowed the auspicious, historical and social term- *Gajaraj*. It is a Sanskrit phone of a millennia old. Our *Gajaraj* has the following major segments A, B, C, C1, C2, D, E, F. Each segments have few sub-segments. It is a 2 stage launch vehicle. 1st stage is termed as *Mahayana*. It is propelled by a specially engineered solid fuel augmented by liquid and gaseous O₂ (see Propellant). The 2nd stage is named as *Akbar* (peerless) i.e. [Peerless + Great Vehicle = *Gajaraj*]. *Akbar* is propelled by a mixture of liquid H+O₂ and separately with other new special use fuels (see Propellant). *Gajaraj* is auspicious. In Hindu system '*Pooja*' means worship and the '*Sawstika*' symbol [N-2] signifies the very auspicious Mahaveer (c.6th B.C.). Therefore we intend to paint a Hindu *Swastika* on our *Gajaraj* as our symbolic signature cum message. Extra terrestrials if any will know that we earthlings know how to worship and we posses and pride in peace, prosperity cum progress, which we extend to them as because we care to share. Our mission is not UFO.

Segment – A

This is *Akbar*, the 2nd stage of *Gajaraj*. It is a direct copy of the temple cranium [Fig. 1 & 2.]. It has sub-segments G,H,I,J,K,L,M,N,O,P,Q,R,S. We discuss all these after discussing, B,C,D, E & F.

Segment – B

This is the mechanical separator segment. When the propellants in segment C have burnt out and the vehicle has reached its orbit, segment A can then fire its nitrogen/bio-genic waste gases propelled liquid propellant engines or our new (i) pyrophoric engine (ii) D₂O/H₂O fractionating engine (page-13). Segment A is 'slid-fit' using grove mechanism onto segment C1. Firing will act on the top platform of segment C1 & separation will happen at position B.

Segment – C

This is *Mahayana* (great vehicle). It is a Sanskrit phone. In the Buddhist order of life almost all modern period faithfuls are *mahayanis* (including Dalai Lama). They constitute a very large segment of peace & freedom loving population on the earth. Our *Mahayana* includes C1, C2, D, E & F sub-segments. Segment C2 contains solid propellant. C1 contains only gelatinous or liquid oxygen or combined with liquid hydrogen. Segment C will fall away and re-enter the material burning zone of the atmosphere. C1 can also be made as non-burn out segment by relocating *segment B* at the separation level of segment C1 & C2. It can later be used in space as refuge/spare external dumping bin or few such cans can be clubbed together to make space habitats or can be dumped on the moon for covering equipments during non use/lunar storms or for building lunar colonies or for making special purpose metal in gravity-less conditions for space colonies by recycling the canister material. We also

propose to re-engineer the canister having a bee hived skin with Ferrite-Hematite-Quartzite-Carbon materials & metallurgy[*]. Compartments C1 & C2 are separated by ultra effective thermal insulation so that heat from C2 does not travel towards C1 when the solid propellant burn. Re-locating our segment B will serve such purposes more effectively. Oxygen should not be allowed to gasify [*]. Between C1 & C2 are numerous suggestive pressure sensitive valves that operate as per requirement of O₂ at burning point. As the rocket starts gaining speed, O₂ will also develop gravity and will be squeezed via the variable gravity sensing valves and force its way downwards, gasify due to heat radiating from the propellant. Gassification of liquid oxygen will increase available volume by many times (for rapid oxygenation) and auto raise chamber compression in C1 via back pressure mechanism (numerous benefits). Excess O₂ will be earmarked for segment A. As in the Parthenon pillars (Athens) and Mouryan Pillar Capitals (India), segment C tapers towards the top and widens towards the base (segment-D). Hence, no portion of *Gajaraja* at any stage of flight through the atmosphere may experience relative dearth of air. Air will be running down its sides. No pockets of relative vacuum will develop. Our monuments (F-1 to3) have at about 1/3rd height (from base) something called *Bada* (fence). After this point the curve aspect of the structure is noted. This means it is a point of re-enforcement. In our *Gajara* the line of re-enforcement (*Bada*) is at the tip of E, graphically shown by a line. In auto pilot mode (without *indonauts*), segment A can also be filled with O₂ for transshipment to space colonies.

Segment - D

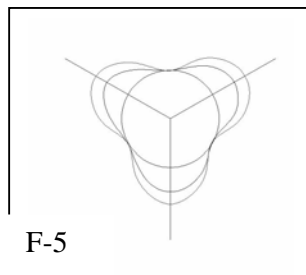

F-5

This is the bottom view of *Gajaraj* (F-5). It is *trisula* (trident) concept. It is a single chamber. Use of metal is planned to be reduced to bare minimum by this concept. We may note fold increase of inner volume. The 3 axis are @ 120° to each. The central circle is the cross section of *Mahayana* at the tip of the strap on booster E i.e. at *Bada*, where the diameter is equivalent to that of the Indian-GSLV's at base. From here it widens in 3 axis

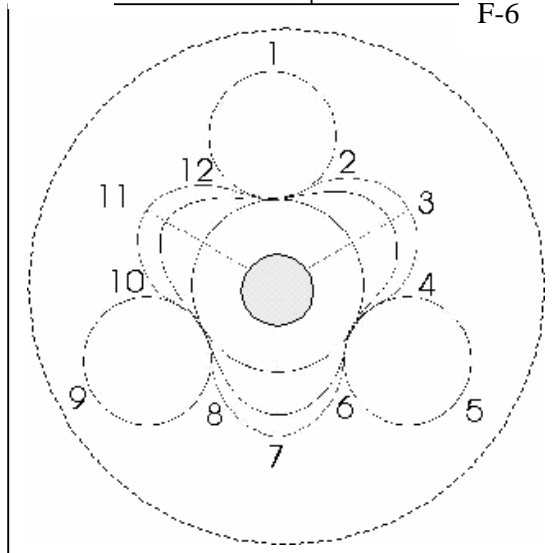

F-6

as in a tetragon. The wavy second inner line is the cross section at mid level of E. The wavy outer line is at D (base). Fig. 6 is the bottom view of *Gajara* when augmented with 3 strap on boosters which are again @ 120° to each other and make an angle of 60° to each of the main frame indentures. All the boosters have identical architecture & dimension i.e. *Gajaraj* has 3 strap on boosters and 3 indentures @ 60°. The downward angulation of the indentures is @ 30°, while the booster is vertical. This allows varied angles of thrust (also scope for vectoring) and fractalisation of vibration in variable angles and directions. Because, vibrations magnify into shock waves via Quadratic fraction route (natural example being ~ seismic transverse waves). Contrarily,

our combination of circular and semi-circular format of variable radius is somewhat reminiscent the π LOTUS [*]. We may also note that a set of any 3 numbers form an inlay of triangles including isosceles and equal angle triangle (which is considered as very tough in engineering structures) and also location 1-12-2, 1-10-4, 1-5-9 from Seriprinsky's Fractals

[*]. Such a design will cancel genesis of internal vibrations, formation of waves and their propagation. Burning tonnes of highly flammable solid fuel in free atmosphere follows a explosive type unstoppable chain action and violent concoctions. Well ordering yet unlimiting the explosion(s) will result in unprecedented pay load capacities. This requires inbuilt design at every stage. Physics & mathematics of architecture, metallurgy, propellant, (every thing) in turn will also enable light weight engineering and fold increase pay-load capacity.

Gajaraj's height is 100meters. At its base it is 3 – 6 times the volume of a Indian-GSLV. A wide circular area will also have low and wider area of center of gravity, which is marked by a gray inner circle F-6. This shall permit straight lift-off, with an heavy head load. We may also find in our design a Fevonasi number [*] in relation to volume and architecture design, to revalidate our theory of stability and best air worthy design. Because, Fevonasi is natural and reckon magic (as alike π LOTUS). We have therefore incorporated cyclic arcs of varying cross section enmeshed with smooth mobious curves of variable pitches [*]. This will help in significantly reducing wind friction (drag), retain planned track and allow fold increase of pay load, which is our paramount objective. The outer circular dotted line is double the area of 'D' (1 : 2). It is the most intense zone of Bernoulli. Air within this circle will be sucked into the flame. The more amount of turbulent air we are able to bring into this region, it will result in better buoyancy + better 1st stage burning [*]. If it tends towards vacuum – Roll, Pitch & Yaw will set in. This design will also help in truncation of the 'drag' into 12 regions [F-6] to around the fire. At point No.1,5,9 the thickness of the rushing air mass will be thinnest, laminar and hard compressed i.e. boundary layer mechanism. While indenture No.1,5,9 will act as pre booster separation rudder [*]. While indenture No.3,7,11 will act as post booster separation rudder. At point No.3,7,11 air will be deeper, thicker and turbulent. At 2,4,6,8,10,12 the air will be highest compressed (injector point), slowest in motion towards fire. These are the point of maximum atmospheric thrust on our design. They also have the maximum metal and counter thrust from the exploding propellant. The 12 stratified air streams will lock the vehicle into the fluid atmosphere mass, allow better track maintenance (no pitch, yaw and roll-?) [*]. The base architecture will allow a much wider fire domain.. It will be of great advantage for oxygenation, rapid burning of very large quantities of propellants, stability, generation of hyper thrust. A bare *Gajaraj* (sans boosters) will be sufficient for quick assemble and launch military/vigilance objectives [N-3].

Segment – E

Our monuments have a design called *Tri-ratha* (tri-vehicles) and *anga-sikharas* (body spires) on the *vimanas*. The strap on boosters are 3 in numbers. They are also taller and larger and total propellant volume is much greater than the 4 strap on boosters of a Indian-GLSV. It reduces metal weight, exposed surface for drag, ensure hyper thrust. They are housed in natural indentures (grooves made by the trident architecture) which reduces drag. The head of each booster is also of *anla* type architecture. Boosters will burn out - separate and reduce dead weight further. At every step we have enlarged our imagination backed concept from observation of extant heritage and have tried to justify with heard concepts and principles of modern science of rocketry. We also hope to realize at least parts of our dream.

Segment – F

David's star format offers maximum surface and a equal expouser to inner volume [*]. From C1 veins extend down wards in David's star format (internal configuration not shown in sketch). The orientation of the veins is along the rocket's side (skin) in the upper sub-

segment of C2, it turns towards the middle in the strap-on-booster segment (below *bada*). The veins are made of mica, because mica traps oxygen in large quantities, can efficiently breath (express) through its skin into the nearby packed propellant. It also offers least friction for liquid O₂ to swift glide. Venous O₂ in liquid form will express into neighbourhood solid propellant. Heat will gasify the O₂ that is in the veins when it descends towards burn zone, this will help in efficient burning of the ultra large volume of solid propellant at all stages of the atmosphere and specially in rarified and in the lesser O₂ zone. High thrust can be generated and maintained all through. We know that (i) with aging (ii) even in fresh solid propellants, as heat and dynamic thrust builds up, the oxidizers may react in unpredictable and in unknown manner (*fugacity*) with other constituents of the propellant resulting in pockets of explosive conditions or uneven/low thrust generating, burn only as debris i.e. inefficient, calling for pay load compromise and higher cost. During assembly, transport and pre lift off or during postponement stage the veins can be charged with gaseous or liquid N or CO₂, which is inert/ fire fighter respectively. Before lift off N /CO₂ can be replaced with O₂.

The ancient curvilinear spires have a *mastaka* (head), a *gandi* (torso) which have 5 *bhumis* (zones/strata), a lower portion called *jangha* & *paa bhaga* (hip & foot), which is demarcated by a line called *bada* (separator). Below the *bada* the build is heavy, plain, with *anga jharakhas* (sidereal windows) in a concept called *tri-ratha* (tri-chariots). Similarly, *Gajaraja* has been conceived to have 5 major segments [Fig-4], a heavy and ultra wide base with 3 external boosters as *tri-ratha* and a trident architecture (*trisula*). The head of the *Gajaraja* has similar architecture as that of our inspiration structures. Interestingly, the head also has some simili with the Kremlin spires (Moscow). We imagine all these as opportunities and take them as inspiration for further opportunistic theorisation.

The Head

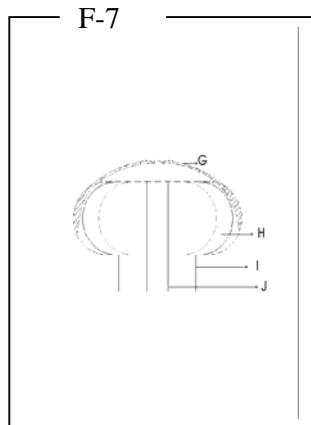

The head [F-7] of the *Gajaraja* (as alike the base) offers a paradigm shift in launch vehicles. It needs discussion. The *khapuri* (cranium) is known as *anla*, because of the rib type architecture as in that medicinal fruit - *Phyllanthus emblica officinialis garten*. We have adopted the terms. Sub-segments G,H,I, & J delineate our variant as in *Gajaraj*. G is the heat shield out-laid with a poly-coat of depleted uranium topped with a coat of Mica of nano particulates, either laid in a cross matrix manner. Mica coat has ripples on its surface. We have observed that the homeless sleep outdoor by wrapping numerous separate blankets. Since they are poor they use hand made blankets of assorted textiles and also rag-tag materials. They refuse to use mono thick blanket. Even if they are gifted with one, they over lay it with something else. The reason we found was that poly coats baffle cold conduction in the inter-coat layers, because every layer of textile has a different heat/cold resistance property. Multi layers may also be making the chill to spread out (diffusion) in the inter-layer gaps and get neutralised by body therm. This type of coat allows a large heat anomaly to be neutralised with a small counter generation. Similarly in arid regions the natives use poly coats of light cotton textiles. In this instance it is outside heat that is baffled from conducting via the shortest route [repeat polarization & phase change phenomena ? *]. Cross matrix poly coat of variable particulate size will ensure better grip, nano layer of gap and also reduce physical shock transmission. The

rippled/wavy mica coat of 'G' will increase the surface area and cause miniaturized level of 'confusion cum cancellation' by not allowing any constant thrust/friction – we guess.

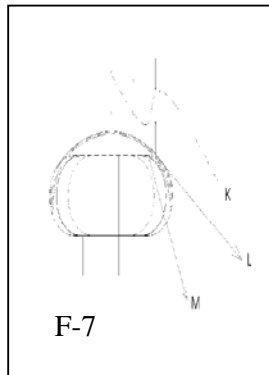

F-7

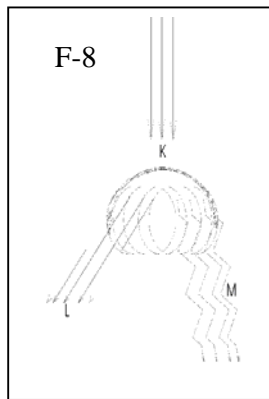

F-8

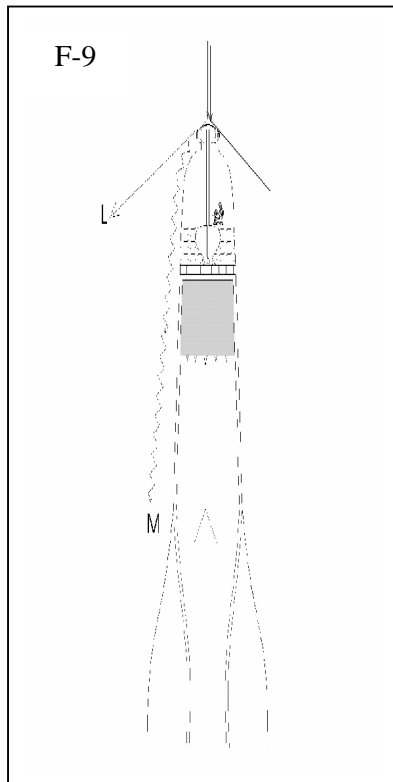

F-9

Our Fig. 1 has 68 ribs (some temples have 72 ribs). Every rib is associated with a niche 'H' having a depth of around 30cms (this too also is our inspiration). We have taken 24 + 24 niches for our *Gajaraj*. It makes the head consisting of 24 ribs and 24 niches @ $7\frac{1}{2}^0$ separation in alternating manner. The circumference of the head will be related to the height of *Gajaraj* and diameter at 'D'. The thumb rule in our inspirational model temples is that the circumference at *anla* [marked by K1 & K2 in F-3] is equal of the height of the spire [F-1] and $\frac{1}{2}$ of the circumference at base (1 : 2). By adopting this ribbed shield we are increasing surface area at the edges for better management (training) of heat and drag – fluid stream. The edges (K1 & K2) will also have thicker and glazed heat resistant coat. The booster heads will have similar architecture and coat.

Segment 'J' is the upper portion of a ion propulsion engine (central-tubule). Segment 'I' is the separator cum 'neck' (*beki*) of the *Gajaraja*. While atmospheric friction will raise the temperature at 'G', at the same time due to opposite action from segment 'I' a near equivalent cancellation forces will be unleashed [*]. In some models the whole 'head' sub-segment can separate and act as a super-multifunctional or a special purpose (spy) satellite or inter colony

transport saucer or as a external maintenance mobile platform. The region below 'I' can dock with the ISS or it can continue space odyssey with or without any *Indonout* or return to earth for re-fit onto another rocket for next sojourn. 'Q' marks the *Indonout*, in Sanskrit we may term her/him as *Mahakaschary* [N-4]. Along with 'H' sub-segment 'I' also multiplies the surface area at top, offers unique curvature so as to withstand very large quantity of atmospheric 'thrust', 'drag' and 'vibration' during 'lift off', by unleashing counter canceling forces at variable rates, in variable angles, from various places as do human neck-shoulders.

'K' are the incident lines of opposition (while lift off), It gets bifurcated into 24 upheavals as it runs over the outer edges of the ribs of the *anla* and at the same time the adjacent air mass sinks into 24 down-heavals as it runs through the adjacent niches of the *anla*. This happens in alternating spaces. This will split the principal force of opposition 'K' into 48 segments of mini drag at a separation of only $7\frac{1}{2}^0$ as flow 'L' & 'M'. $7\frac{1}{2}^0$ is also a natural selection. We can see 'K' demonstrates the type of

bifurcation cum turbulence that is likely to precede continuously ahead of the rocket head.

Turbulence is opposite of high dense stratified layers of winds [*]. This is turbulence of large scale induced by our choice architecture. Turbulence set off by 'G' is of mini scale. Segment 'I' also triggers another set of turbulence and cancellation force. As the *Gajaraj* accelerates upwards, the air mass above gets compressed (high pressure). Our aim is to knock off the high pressure by design. The up-drive force and pay load capacity of the *Gajaraj* will get multiplied. We are told that, turbulence or infracation [*] of the pressure transmission lines creates low pressure, because our home region is annually effected by numerous tropical cyclones that are also declared as 'low pressure high turbulent systems' (our inspiration from nature). 'H' represents the niche. As the wind races through the niches it will run down in turbulent form as in 'M'. It will have comparatively less flow speed, pressure, and will 'hug the body of *Gajaraj*'. While the 'M' layers will with ease be available for burning, 'L' layers will act as high dense conical stratified boundary layers (see Fig.3) and shield the weaker turbulent flow 'M' from developing pockets or expanding in undesirable manner [*]. We think of re-engineering boundary less, friction-minimised fluid in-flow towards the burning point [*] instead of being away from body due to rocket speed and a thinning atmosphere [F-10]. In conventional launch vehicle propulsion the layers of air do not inter-act. Stratification become a bane. We by design intend to re-engineer the wind flow so that a side-fill interaction may set about from the outer layers 'L' towards the inner layers 'M' and then towards the burning point. This will reduce depletion of liquid O₂, which can be used during space colony building.

Space Ship - Akbar

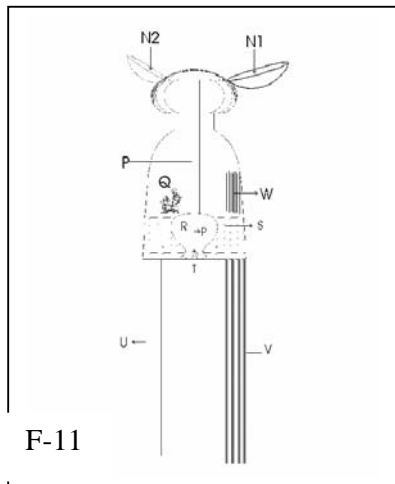

In outer space, our heat shield 'G' is to open up as a 2 layered hatch. 'F-11' represents the position post separation. We name it *Akbar* (peerless). The heat shield have opened in 2 layers in opposite directions. N1 is the outer and N2 is the inner shield. The parabolic inner curve (greater area) of the either shields are inlaid with nano, micro & macro tubules. These tubules are made of activated charcoal (carbon). The tubule array and the depleted uranium shield act as the anode and the cathode pair. The carbon tubule array are tough, hard to destroy, light weight, organic, conductors have a very large micro-porous system and surface area, which will efficiently attract and trap ions from the ionosphere and electron-volts from the space. The tubule array are connected to 'P', which is a *very large* ion propulsion engine. Since the lumen size of every tubule in N1 & N2 keep on increasing in a graduated manner towards 'P', the neo trapped ions (in the nano tubes) gravitate towards 'P' under para-magnetism assisted by graduated increase in electron volts[*]. Segment 'P' is comprised of sub-sections which have variable alloy composition (metallurgical) and are permanently magnetised in a stage increasing manner (alloy property). Wishfully, we can attract Neutrinos at N1 & N2 and send them charging through a graded sub-radio-active propulsion tubule in batches as gusts or into a store pre regulated ejection to generate a thrust.

In villages people carry material on chest, shoulders, back and on head. 'O' is the 'head load' space of *Gajaraj*. O is the space inside the 'head' (not shown). The dotted line between N1 & N2 above 'O' is a mechanised hatch back cum platform for mooring various apparatuses which can be used for open space assembly work. 'Q' is the Indonout. He has a very large goods bay cum work station for critical research [*]. This space can (also) be used to ferry liquid O₂ to ISS or to the space colony and also ferry very large satellites in knock-down condition and re-assembly in space using only a screwdriver. 'W' represents 2 types of space colony building pre-fabricated material. One for main frames and the other for outer walls and separators. Our plan is to use human labour in construction of space quarters & colony as much as possible in order to save energy and re-direct such saved energy for wider inhabitation.

What natural observation encourage us to plan such large and heavy head ? In our forests there are natives called *sabara(s)*. They use bow and arrow to hunt. We examined their device and found that the weight of the head of a arrow is much more than all others parts put together ! After days of trying out with bows & arrows we found that as we load a arrow tout on a bow all the lines of force get aligned into the arrow. While the weight of the arrow is transferred on to the bow & the string and the shooter, all the potential force gets injected into the base and gets loaded into the head i.e. amount of force at base is transferred to the head as *momentum* [*]. So long the rate of transfer of force from tail into the head is higher than the speed (velocity) of the rocket/projectile...gravity will be overcome [*]. We may say, as segment 'D' keeps on generating higher thrust with every passing kilometer, it will also be transferring thrust into segment 'A' at a increasing rate. It means the effect of gravity on *Gajaraj* will be reducing at a increasing rate.

Space Housing & Colony

In space structural rigidity, heavy build are redundant due to weightlessness of everything. Therefore, 'W' are architectural forms that can create large living rooms / small-working dormitories. The concept of small rooms e.g. Bee hives, etc, will be uneconomical. In our view Bee hives are good candidate design for skin (outer cover/also for architectural). In space, exposure to solar radiation (heat) is constant so also to radio-active rays. Therefore, 'W' is poly layered material. Since Akbar is hollowed on both sides and can also be opened out at segment 'I' a series of Akbars can be configured in space as a quick build colony. This is if we do not abandon segment C1 as empty canisters i.e. *Akbar(s)* need not return back to earth and hence need not have the extra weight of re-entry material/coatings (which is heavy). We may also consider the following. In a vacuum chamber, on a primary layer of 1mm Teflon sheet, thereafter a layer of glass wool of 2 mm thick is to be laid in a dense ordered manner made of nano particulates be sprayed under low pressure (Teflon and Mica do not de-gas, have very little photo electric effect, hence we have indulgence for such group of materials). Teflon is the outer side. We then spray a layer consisting of depleted Uranium or Lead at low temperature ~ 0.5mm thickness as shield from radio rays. Laminated area to be filled (in space) with biogenic CO₂- to act as Fire-extinguisher and for expiration by plant & trees. Atop this we spray a mixture of hay powder + gypsum for another 1.5mm as insulator (torrid wetland rice hay and not wheat). This is the inner side. Total 5 mm. This should suffice as walls, floors, for riveting, for driving in of fasteners and for special regions double or triple layers of cut sheets etc., are imaginarily envisaged. Both trap CO₂ & SO₂ (we learnt this from Indian village life). The hay powder + gypsum ages. Therefore they can scrubbed and thrown

out (even re-cycled). The colony will have to rely extensively on radio waves for internal communication. The combination of hay powder + gypsum will also adsorb various frequencies and prove beneficial.

We will also consider transporting composite rolls of Teflon-Mica-Fiberglass- composite cloth of 4-8 mm thick / 2.5 meters wide and then in space unroll them on bare frames structures (assembled with pre-fabricated ultra light, press stressed, internally honey combed & energy convertible jelly filled bars). The laminates be filled with bio-genic wastes e.g. CO₂ @ 400-600 hPa. A device will suck expired CO₂, and store it in the skin of our colony, which can be used to douse O₂ generating bonsoi oaks & birch trees (doubling up as fire-extinguisher). These species of trees are possibly most efficient generators of O₂. Plants will not express O₂ without a combination of UV and CO₂. Use our *Akbar* to undertake leak proof and radio rays shielding coats (from outside). Inside our soft, cushy space home pressure be ~ 600 – 700 hPa (the requirement for ‘feel good’ lung function). O₂ pressure is not that very important (as it is thought – talked about in Web articles, books, etc.). It is the overall atmospheric pressure that is. Why and how ? When the overall colony atmospheric is of the order 600 – 700 hPa the pulmonary aveoles experience a balanced osmotic thrust (assisted by the contraction of the Thoracic cage) and all types of blood gases is expressed out. In exchange O₂ is uptaken selectively. Because lung tissues exhibit/ behave in current position dependant design (brain controlled) affinity for O₂. For example, up in the Himalayas, air pressure is low. The pulmonary tissues slacken. This allows other gases to also pass the tissue barrier into the blood. *Hypoxia* sets in. Atmosphere pressure is low. The thoracic goes into a over-ride. Higher volume is expired and (relatively) less O₂ is inspired. A syndrome sets in. Mouth breathing sets in, involuntarily. Most of the time the lips are apart. Heart rate will also go up. No good, No good. Give O₂ and everything returns to normal. For optimum uptake of O₂ efficiently by blood via non assisted normal pulmonary mechanism, O₂ pressure inside the chamber need not be ‘high’. It is the overall chamber pressure that is dominantly important. This is because pulmonary tissues contract variously to express various blood gases, which is miniscule amount, yet is expelled at same thrust as is CO₂ expelled. Larger amounts of blood gases (which is very rare) are expressed via the anus/urethra route. Higher amounts of desiccated O₂ will also increase thirst. Is detrimental in very many other ways. Whereas, CO₂ retains moisture. Carbon (particle) is the best moisture/droplet condensation cum collation candidate nuclei. CO₂ is a friend, in disguise. Certain foods assist blood gas accumulation. Certain foods extrite via the gut route. We discuss that in another communication. We try to discuss all these things by raising the question (much alike the ancient *Rishi*), what does nature do to itself ?

Out side the colony the pressure is zero. Therefore, external non metal walls may require additional re-enforcements (to avoid burst & pressure leaks) which we will provide with ultra light weight flat silicon/teflon tubes wound loosely around filled with H₂O for biogenic use. Use special pumps (peristaltic [*]). Micro and macro sized wafer thin tracks of polarized graphite can be embedded as cable/conductors (on both sides of any separator or exterior wall of our colony). This will further reduce electrical & electronic connectivity item caused weight. The Sun side is also the radio ray side. Our entire space colony/housing will have a layer of solar panels (as do modern buildings have sun films), which will act as complete Sun-heat & also shield, radio rays & excess light effecting the walls of the colony [photo electric effect *]. The solar panel will be photo-magnetically, photo-sphere positioned (Sun center), i.e. all other sides of the entire space colony/housing will never face the Sun. This will help us in reducing weight on the other sides. We may call such a colony as *Xanadu* or *NaduX* (experimental *nadu*). The term *nadu* means a ‘culture full country’. It is an ancient

Hindu phone. The term *Xanadu* is taken from Lee Falk's fiction abode of Mandrake the Magician. In *Xanadu* most imaginative, useful experiments and products will be made that will appear as fiction on earth.

Alexander the Great had attempted what others had not. He told the west how mighty India is. 'R' is a 'dual core' firing engine. It does with might what others cannot. We name it Alexander. We have picked the term 'dual core' from computer advertisements [*]. In zero gravity ion explosion (non destructive, non burning) may be possible by loading of chamber 'R' with ions and applying O₂ less heat at expulsion end. 'R' can separately work only on ions and again only on 'S' (liquid H+O₂) combustion or in combination. 'T' is thrust vectoring apparatus. 'U' are a set of long-large retractable dangling solar arrays. They produce lot amount of power. In propulsion stage the arrays may be folded back and in its place 'V' can be dangled out. It is made of carbon filaments for re-trapping the expelled ions (from 'T'). Component 'V' is behaved with nano tubes to re-cycle expelled ions least in part. Akbar the Great used the best of Hindu generals to often subjugate without a fight many a Hindu region, lo our inspiration ! Our Akbar the 'peerless' is a matchless recycler of excited-accelerating ions. N₁ & N₂ are winnow type ears as do tusker have. In Urdu & Arabic we may say *Akbar ea Gajaraj* (Peerless is the Tusker Lord).

The *Gajaraja* transpires out of the tusker which has a super large belly cum heavy hind and a relatively small & light weight cranium. Hence, nature has provided it with a heavy & long proboscis – to balance the structure. The tusker can breath through the mouth and also via the proboscis. Thus we gather our lesson. We have increased the volume of solid propellants (bottom) that will burn in atmosphere and generate thrust which is also many times more (gravity region). We have also provided a internal breathing mechanism with adequate stock and store of oxidiser. We try to imagine what nature does to itself and apply to our concept and present it to the reader as if a well made design.

A space colony will be generating significant amount of bio-genic wastes, of which we know water is re-cycled. We are now working on a similar inspiration based imaginary concept to produce automation inducing power from water, and a near or real super conductor, which we also intend to discuss in a subsequent project.

Propellant

For Mahayana

We may now consider special propellant(s) for our very special *Gajaraj*. Our objectives are (i) burning be well ordained (complete) (ii) ultra-hyper thrust (iii) more safe (iv) light weight (v) economy (vi) other down stream benefits- Ph.Ds, employment, etc.

(i) Segment C (inlaid with mica vein architecture) is to be wrapped in a suitably insulated, liquid proof magnetic coil which can induce a magnetic field in the whole of the interior of C₂. The whole is then to be immersed in a giant bath of Acetone (standing position). This fluid is highly volatile, colourless, suggestively inert against our propellant (see below) will allow quick sink of macro sized propellant. Magnet has to be switched on. Stabilise for 30-60 minutes. Propellant has to be dropped thereafter into the canisters (rockets) through the magnetized acetone bath. Periodically mechanical compaction has also to be done in a very light manner say @ 300-500grams per square cm., or by using the principles of very high

hydrostatic pressure. High compaction = ultra hyper thrust. Acetone is also a binder and has many other good effect on compatible propellants. Topping exercise has to be done from 'B'. Due to magnetic field the propellant particulates buoyant in acetone will settle in a polarized manner. Post semi-loose filling under acetone bath, the magnet has to be switched off, and the filled rocket to be taken out to dry and self settle. Polarized propellant will burn extra smoothly generating a white-blue flame having a high colour temperature, will generate ultra high thrust and also require relatively lower amounts of oxidizer [*]. Wishfully, using almost thrice the amount of solid propellant that is used in a Indian-GSLV, our tall and mighty *Gajaraj* is conceived to deliver 10-20MT of indo-international space load into geo-stationary orbit or beyond i.e. on to lunar surface.

(ii) We know that in launch vehicle solid propellant constitute most of the weight which is due to specific gravity. Semi-loose filled polarized propellant will reduce weight. We also intend to change the chemistry and introduce a new light weight chemistry having constituents of less specific gravity and high burning and high ignition point = safety + explosive power post ignition. We will also try to work out a light weight, high mass, semi-hard gelly (H & O₂ in gelly form) which will enable best oxygenation, generate higher thrust without explosion. Wont re-act with liquid O₂, have long shelf life. Because space colonies will require serial production and firing of rockets (goods carriage). We will consider seriously to polarize / magnetize all our liquid & non-liquid propellants.

We may consider the following formula which again we have borrowed (from community). This is volume based formula.

1. Potassium Perchlorate - 1 - micronised ~ 200 mesh
Mix thoroughly
2. Aluminum pellets - ½ by vol. of No 1 ~ 50- 100 mm (75%)
Mix thoroughly
3. Aluminum powder - rest 25% micronised ~ 100 or 200 mesh.
Mix thoroughly
4. Sulphur - ¼ by vol. of No.3 ~ 200 -400 mesh
Mix thoroughly
5. Drop via acetone binder bath.
6. Apply compaction ~ very high hydrostatic pressure, when material is wet.
7. We will also experiment by adding 10% welding electrode material.

For Akbar

In vacuum we also propose pyrophoric chemical compounds be dry sprayed from nozzle No.1 and biogenic wastes (indonout's) from nozzle No. 2., from nozzle No. 3 recycled O₂ to be injected. A 3-9V DC power operated plug can provide the spark (as in scooter/moterbike) for continuous combustion. This will ignite the pyrophoric which will provide high propulsive thrust. It can be used to de-dock from the ISS or for internal separation of sub-segments of the *Gajara* or for landing and take off from lunar surface. This is apart from the standard cryogenic fuel which is heavier, requires more special engineering, time, money, labour and generates comparatively less thrust.

Metal Casing

F-12a & 12b

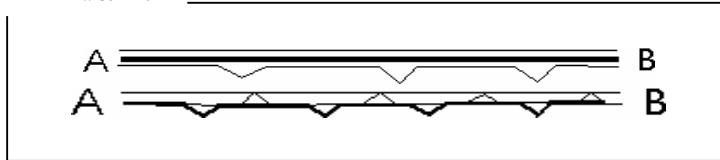

Our temple is full of triangular art and designs. We take further cues. For the casing of the entire segment C [C1 + C2] we may consider a alloy laminate

of 3 layers of variable thickness 1, 1.5 & 2mm, each having variable proportion of Aluminum - Chromium - Iron.. Chromium-Aluminum-Iron will also act as propellant at burning stages. India has large rich deposits. We have heard [*] that thrust is highest at curvature. The canister has a continuous curve, hence every point experience maximum out-ward thrust from

A loaded propell: B more so during burning stage (high G). Our idea is to make the inner sheet thickest, the middle the least thick, the outer should be more thick than the middle and less than the inner. F-12 or F12a, give a schematic presentation (variable types). One side (face) of the sheets to have macro sized triangular sinuses, which in Sanskrit is known as *Tribhuja* [F-12a, & 12b]. We know triangles are design that have great strength and can withstand high thrust. The sinuses extend from 'B' to 'D' [F-4]. 3 such sheets be laminated to form air breathing skin for *Gajaraja* during 'Lift Off' & 'Flight' stages. This is also large space for storing O₂. We guess, that speed of air outside the rocket will be more than the

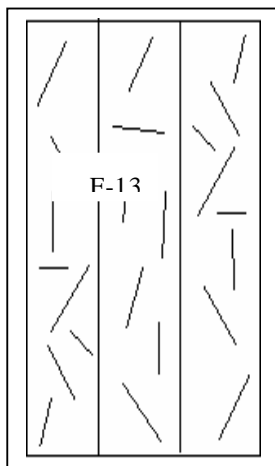

speed of air flow in the sinuses. This amount of air and later on O₂ will be additionally available at the nearest possible point of burn/fire, assist better burning. It will be low compressed from within and high compressed by the out side high speed wind flow. It will stop propensity of the fire to spread outwards i.e. controlled. High speed air flow from position 2,4,6,8,10,12 [F-4], will interact with *low speed skin flow* to get fast diverted towards 'Fire'. Jointly or severally may multiply thrust as in 'Back-Burner' effect in jets [*]. The space between 2 sinuses (corrugates) on the propellant side will be laid with mini bars of different metals and alloys in different angles at different spacing F-13. This will fold increase stencil, load bearing, cancel enlargement of vibration and stress wave propagation (towards any relative weak points if any or as many). This inspiration also comes from the temple [*]. We

imagine our concept may eventually cause weight reduction, increase vol., economy, better fuel burn-thrust efficiency. Which will be a great boon. Diamond is the hardest substance and is the most prized jewel. We may term the whole as *Tri-Ratna* (three jewels). The *Shiva Linga* also has a *Tribhuja*. The symbol of Ganesa is *Tribhuja* (delta).

Water Fractionating Engines

Space settlement and colonies will be marked by 2 aspects (apart from others), which need sustainable solutions. They are (1) Generation of considerable volume of biogenic wastes in liquid form (2) Ever increasing energy requirement. We know, energy induction effects a direct transfer from liquid to vapor state and even to gas. Frothing is the intermediate stage in such pathway. Which is why, forth and surf decorate the crests of waves, breakers, in shore sweeps and in lyophilising industrial processes. Let us conceptualise a ultra super charge state i.e. momentary induction of energy far in excess of the amount any given mass can

retain. In gravity less condition this is more convenient. Our starting candidate is deuterium oxide, D_2O or 2H_2O (~ similar series of engineered Heavy Water (HW) or even ordinary ionized H_2O). The issue is, can we super charge HW vapor in (near) weightlessness condition to get fractionated D_2 and O, bypass the flame dousing phenomena and arrive at a fuel + oxidant for induced ignition ? HW can constitutionally further be re-engineered, charge potentiated (electrolysis), ionized - polarized (magnet), and ultra super energized (state) by inducting a very high value mechanically impulsed force (critical) onto its accelerating vapor i.e. at inertia (tubule : as in accelerator) at ambient temperature(s). Momentum is mass dependent. Vaporisation creates particulates of variable mass. Ultra acceleration (ultra high turbulence i.e. absolute Reynolds), of variable mass will thwart stratification, mass value based segregation ~ conjugation. Treating the same with heat and shock waves may lead to differential impression and retention of energy from moment to moment in the D_2 and O components respectively. Differential build up of momentum, realignment, loose/proto fusion and/or result in differential internal vibration, its propagation, concoction at bond boundaries, bond weakening (bond mechanism failure), early attainment of proto gas stage brink, cracking, eventual gasification (amorphous gas?) ! Collision may also be profitable. Loose/proto fusion may be collateral opportunity. Mankind does have the fiscal resources, chemical and mechanical engineering wherewithal to re-engineer natural water so as to make it preferred candidate for internal bond lysis when exposed to shearing stress. But, fluids do not experience shearing stress. Which so far has been the baffle. However, gravity less total environment is the opportunity i.e. in weightlessness water do not conform with Newtonian parameters, in spite of being fluid sourced. The principles of fluid mechanics stand infracted. Induced arching will also generate cyclic relative high pressure i.e. a looped process. Theoretically, HW(s) positions as fuel candidates. Multi-lateral effort is warranted[*].

Acknowledgement

We thank our father Dr. Deepak Bhattacharya for having provided most of the temple related inputs, for having edited our writing many times over and giving it a essay type shape and form, for encouraging us, for refining many of our crude & crass ideas, for explaining to us most of the technical aspects, for providing many technical terms [*] which makes this *essay of imagination* a bit realistic and for giving it a presentable narration & rocket flight language [*]. Computer engineering student Priyanka has also helped us. Our teachers and others have concurrently edited and have continuously encouraged [*]. We thank Mr. T.B.Sahu c/o Kiran Computers and architect P.S.Naik of Rhythm Architect for the drawings to our liking. We have learnt Power Point at school. Author No.2 had presented the concept (only) orally using self designed Power Point at Young Astronomer's Talent Search on 12-12-2007, at Bhubaneswar, India, representing her school - St. Xavier's High School, Kedar Gouri, Bhubaneswar-India. We then had 8 images (now 13). It was not appreciated by the learned honble. Judges [N-5]. Ordinary people loved our concept and encouraged us. One visitor had advised us to join NASA student's contest. He provided the address. Which we do. We wish to thank him personally (however we do not know him) and also thank NASA for having encouraged us when we contacted them. We have taken more than one year preparing this idea into a presentation. We have spent our pocket money to prepare this. Since English is not our mother tongue we therefore exhibited our work to numerous people in an attempt to get it refined. Over and over editing was done by our father [*]. We are grateful to all our seniors and thank all.

We can give a talk on our model using Power Point.

NOTES

1 - We have been working on *GAJARAJ* since over 4 years. To participate in NASA contest we redoubled our efforts and have been preparing our write up for over 1 year now intermittently. In the process we picked up technical terms to justify our concept. We do not understand the meaning and application scope as much we do not understand the technical terms and phrases that we have marked with [*]. However since we have been at this task with mindful intention, indulgence and under guidance we have picked up some vague understanding. The original inspiration is ours 100%.

2 - The Nazi Swastika has opposite turn of the Hindu Swastika. The Hindus used the Swastika from 2nd – 1st millennia B.C. *Swastika* means the cumulative meaning of august + auspicious.

3 - The Russian Soyuz also appears some what similar from front elevation and also from bottom view !

4 - Acharya means ‘professor’ ! India has numerous types of *acharyas* viz. *Vedacharya*, *Tripitakacharya*, *Sivacharya*, *Siddhantacharya*, *Rangacharya*, etc., and also *Bhattacharya* (the most populous sub-group). *Mahakash* means ‘space’ and *chary* means ‘rider’. Therefore *Mahakashchary* means ‘space rider’, which also has commercial viability aspect. It has nothing to do with the meaning and scope of Acharya the professor. It is another instance of inspiration derived imaginary product as is everything about our *Gajaraja*.

5 - At the Young Astronomer’s Talent Search-12-12-2007, held at the planetarium, Bhubaneswar, India, hundreds of ordinary people had loved my concept. At least one learned honbl. judge had told author No.2 that *Gajaraja’s* concept & design was all flawed and another learned gentlemen from the government had told that 2 stage launch vehicles were well known concepts and that we had nothing new. We had felt discouraged, not our teachers. Almost in all technocratic levels in India our ideas has been outright rejected. However our learned teachers think that we have something very Original, imaginative,

6 - We had also submitted to NASA on 10-02-2008 (after due correspondence –via e.mail). However, it seems it did not reach the destination at all OR did not reach on time OR was pilfered. Therefore, we submit afresh – 2009 Contest.

7 - We have been actively working on Gajaraja now for over 4 yrs.

8 – India and the USA are gradually getting closer together on numerous civilisational and global strategic matters. Space colonization is among the top strategic areas. Therefore, translating ancient (forgotten/unknown) oriental concepts & ideas into applied models, power-packed, economic manufacturing, efficient joint command and control, resource personnel exchange, and launching of vehicles will also become a common area of interest, because of natural complementing advantages that the two nations have. Our concept/idea *Gajaraja* is finger towards such direction.

To

Dr. Bryan Yager or Wenonah Vercoutere
At - MS 236-7, NASA Ames Research Center
Moffett Field, CA 94035, USA.

Sub : **Nasa Space Settlement Design Contest : 2009**

_____ Dt. of birth 11-03-1991, Std. XII

Signature of Author No. 1

Author No.1 is a bonafide student of a Government Junior College.

Add – C/o The Principal, B.J.B. Junior Collage, Lewis Road, Bhubaneswar, Orissa, India, 751002.

_____ Dt. of birth 02-11-1993, Std. X

Signature of Author No. 2

Author No.2 is a bonafide student of a High School

Add – C/o The Principal, St. Xavier's High School. Kedar Gouri, Bhuabeswar, India, 751002.

Signature of Miss Pooja & Swastika Bhattacharya are attested.

The contents of this submission is their original work.

Total 15 pages including this. 6965 words. 13 Figures (+1 as a full sheet enlargement).

Principal

Candidate's Full Permanent cum Present contact Address in India is :-

C/o Radha Krishna, Kedar Gouri Road, Bhubaneswar-751002, India.
Phone 91(0)674-2430407 (Resi), E. mail (pp)– oddisilab1@dataone.in